



SAMBA

WP 4 – Infrastructure

Deliverable 4.2.1

Architecture of the Return Channel

Reference:	SAMBA/PUSP/wp4/4.2
Category:	Report
Author(s):	André Hirakawa, PUSP , Moacyr Martucci, PUSP, Andreas Zoeschg, DIGILAB, Elena Bensi, DIGILAB
Verification:	Oscar Mayora, CN
Date:	30/09/2007
Status:	Final
Availability:	Public

Document History

Version History

Version	Status	Date	Author(s)
1		Sep. 14	André Hirakawa
2	Final	Sep. 30	Oscar Mayora
3			

Contents

1	Introduction	5
1.1	Finality of this document	5
1.2	Scope	5
1.3	Definitions, Acronyms and Abbreviations	5
1.4	References	5
2	SAMBA ARCHITECTURE	7
2.1	General Architecture	7
2.2	PLC as Return Channel	8
3	POWER LINE COMMUNICATION (PLC)	10
3.1	Introduction	10
3.2	PLC Coding	10
3.2.1	Coding and Channel Quality Monitoring	10
3.2.2	Bit Error Rate	11
3.2.3	Performance	11
3.3	Channel Adaptation	11
3.4	Spectral Efficiency	11
3.5	Layer 2 Protocol Description	11
3.6	MAC (Media Access Control)	12
3.6.1	Access MAC	12
3.6.2	Medium Voltage Access MAC	12
3.7	Traffic Prioritization	12
3.8	Bandwidth Allocation	13
3.9	QoS Quality of Service	13
3.10	Security	13
3.10.1	DES / 3DES Encryption	13
3.11	Supported Services	14
3.12	PLC Configuration and Network Management Mechanisms	14
3.13	Radiation and EMC	14
3.14	PLC Architecture Overview	15
3.14.1	Network Topology	15
3.14.2	Class of Service Configuration	16
3.14.3	Limiting MAC Addresses	16
3.14.4	Quality of Service	17
4	PLC Return Channel requirements - Barreirinhas and Natz	18
4.1	Return Channel	18
4.2	PLC and QoS Specifications	18
4.2.1	Bit Error Rate	18
4.2.2	Performance	18
4.2.3	Spectral Efficiency	19
4.2.4	Maximum Throughput	19
4.2.5	Field Measurements	19
5	PLC Return Channel Architecture	21
5.1	Introduction	21
5.2	Design considerations	21
5.2.1	Barreirinhas Site	21
5.2.2	Natz Site	23
5.3	PLC-RC Architecture Proposals	25
5.3.1	PLC-RC architecture proposal for Barreirinhas	25
5.3.2	Technical Specification and PLC Infrastructure for Barreirinhas	26
5.3.3	PLC-RC architecture proposal for Natz	28

6 Conclusion of PLC architecture for SAMBA 29

7 Summary of the document 30

1 Introduction

1.1 Finality of this document

This document presents and studies accomplished to fulfil the lack of functional and technical requirements information required to define the architecture of Return Channel (RC) based on Power Line Communication (PLC).

1.2 Scope

The document comprises the following sections: Interactive Digital TV (IDTV) requirements, required bandwidth for return channel, general information architecture and PLC-RC architecture.

1.3 Definitions, Acronyms and Abbreviations

BER: Bit Error Rate

CPE: Customer Premises Equipment is the actual PLC terminal, which connects the user device.

HE: Head End is the PLC equipment that coordinates, as master, PLC terminals (CPE) connected on that.

iDTV: Interactive Digital TeleVision

MAC: Media Access Control

OFDM: Orthogonal Frequency Domain Modulation is the method that allows several channel transmission in the same media.

PLC: Power line communication describes a system for using electric power lines to carry radio signals for communication purposes.

QoS: Quality of Service

RC: Return Channel

STB: The term Set-Top-Box describes a device that connects to a television and some external source of signal, and turn the signal in content then displayed on the screen.

1.4 References

[AMODEI] A. Amodei, et al. "The ad hoc return channel: a low-cost solution for Brazilian interactive digital TV" IEEE Communications Magazine, vol. 45, pp. 136–143, Jan. 2007.

[AZIMI] M. Azimi, R.K. Ward and P. Nasiopoulos "New interactive services for digital TV" in Proc. of International Conference on Image Processing, 2001, p. 817.

[CASTRO] E.R.S. Castro, M.S. Alencar, F.B.S. Carvalho, D. M. C. Filho, "On the use of Power Line Communications to Transmit the Return Channel for Digital Television" in Proc. 2006 IEEE

Ninth International Symposium on Spread Spectrum Techniques and Applications, 2006, p. 381-385.

[CHANG] Chang-Kuan Lin, Hao-Wei Chu, Shiann-Chang Yeh, Meng-Ting Lu, Yao, J. and Chen, H., "Robust Video Streaming over Power Lines" in Proc. 2006 IEEE International Symposium on Power Line Communications and Its Applications, 2006, p. 196.

[CORINEX] - Corinex Medium Voltage Access Gateway/Regenerator – www.corinex.com

[ILEVO] – Ilevo PLC system, structure and components – www.ilevo.com

[HOMEPLUG] - Homeplug Powerline Alliance – HomePlug Technology Field Test Results – A White Paper. 2003

[HRASNICA] H. Hrasnica, A. Haidine and R. Lehnert, Broadband Powerline Communications Networks, 1st ed., West Sussex, England: John Wiley & Sons, 2004.

[HRASNICA2] H. Hrasnica, R. Lehnert, "Powerline Communications for Access Networks -- Performance Study of the MAC Layer", III International Conference on Telecommunications BIHTEL [Online].

[FRORESCU] D. Florescu and J.M. Hasemann, "Interactive TV and Mobile Communications: New Dimensions for Value Added Services" in Proc. The International Conference on Computer as a Tool. EUROCON 2005, 2005, p. 112.

[LIN01] - Lin, Y.; Chlamtac, I. Wireless and Mobile Network Architectures. John Wiley and Sons. 2001. 532pp.

[MHP-GUIDE] - The MHP-Guide, A comprehensive Guide to the Multimedia Home Platform, the underlying technology and possible uses.

[MHP-USABILITY] - MHP Usability and Style Guide, Christian Noss, Petra Gersch, Thomas Hofmann (UDE), Tim Koch (DW), Bjoern Stockleben, Nico de Abreu (RBB), Ali Chouikhi (PCE), March 2006.

[SAMBA D.2.1.1] Report of the Users' Needs including Requirement specifications Document (May 2007)

2 SAMBA ARCHITECTURE

2.1 General Architecture

The main objective of the SAMBA project is to create a framework that allows local communities to use Community Access iDTV Channels and citizens, including low-income population, to participate to them and use their services. The resource platform of SAMBA allows the development of innovative interactive applications focused on social local communities: services, locally created, could range from purely informative to interactive, including applications with a strong social focus, such as eLearning, eHealth, eGovernment.

Figure 1 shows overall architecture of SAMBA and the main players involved.

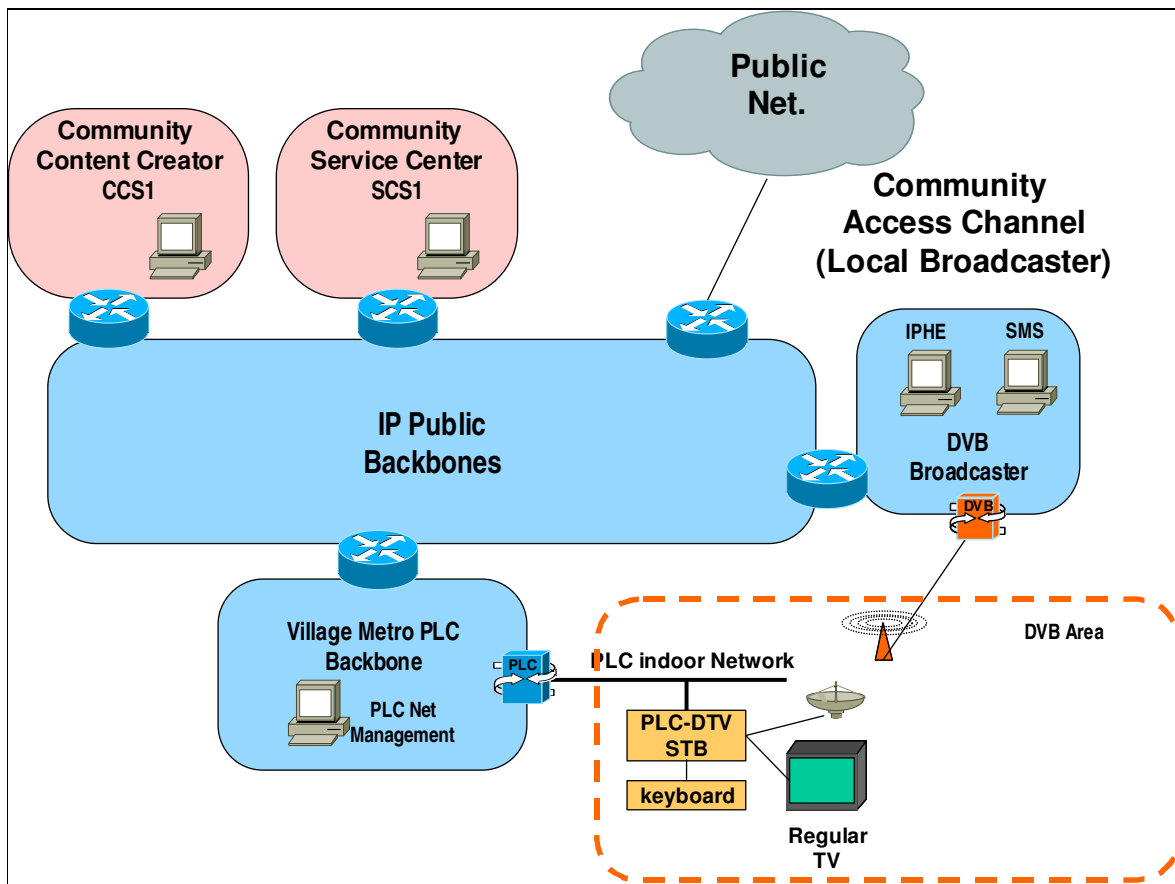

Figure 1: SAMBA Architecture

In the Figure, a **Community Access Channel** is a general iDTV channel that broadcasts all content and brings together content independently produced by various communities that is represented by **Community Content Creator** and **Community Service Center** units. The content and services sample are as follows:

- Schools;
- Administration of small towns or regions (like rural or alpine communities);
- Public services (public library, local hospital), Public, Educational and Government (PEG) television;
- Interest groups (sports associations, church communities, socially active groups and organization ...);
- Any community that has interest in delivering content and information on a local basis.

Also in the figure, the dashed box represents the main Return Channel for Primary Users that is implemented using PLC technology. The PLC network interoperates with local IP network by the use of a network management system mainly composed by a Network Bridge.

In a general application scenario: content creators produce content for iDTV through Community Service Center Web portal that allows them to access the Content Creation Factory. Updates to the content can be made through Internet. Primary users can access the Community Access Channel content not only through iDTV, but also through Web and mobile phone, and can interact with using Return Channels, such as PLC, mobile and Web.

Figure 2 shows the network architecture point of view.

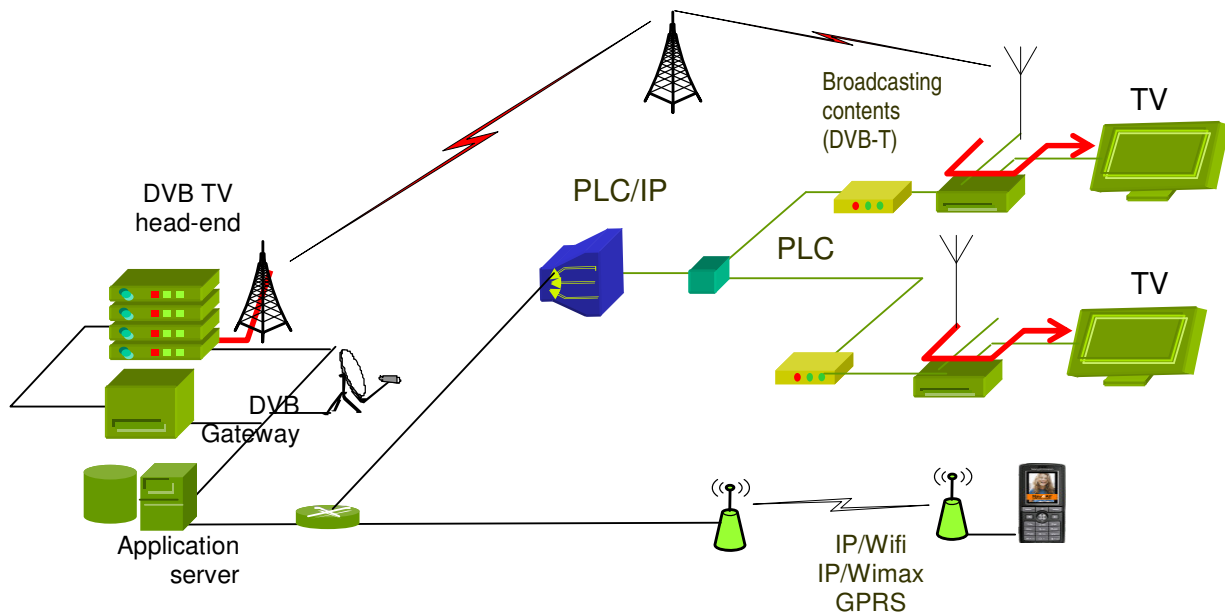

Figure 2: Network Architecture

2.2 PLC as Return Channel

In order to reach also low-income population, and to provide them access to the delivered services and to iDTV technology, a low cost solution will be considered. In particular, for guaranteeing a fully access to interactive services, a return channel must be available to the user, and for part of population this extra cost can be an issue. Indeed, the return channel is the major problem of any iDTV initiative.

For addressing it, SAMBA proposes the utilization of **Power Line Communications (PLC)** technologies for the Internet connection of the iDTV Set-Top-Box (STB) receiver.

The Brazilian powerline network covers almost 95% of populated areas. This coverage is much greater than telephone and other data networks. The previous is specially truth on areas that presents high social demands, in which, there is few or none offer of services. At those places, the power distribution is generally the only structured service offered by the government.

The definition of an end user solution for receiving iDTV content able to use the PLC network as a Return Channel, can lead to an extremely important experiment in the creation of a Digital Village, with connected houses holds and other indoor system.

SAMBA uses as a test bed two main locations:

1) The **Barreirinhas** site in the State of Maranhão, in the northeast of the country, were recently a PLC backbone has been implemented and tested. A bi-directional satellite link brings Internet connection to the ground, and a gateway takes this connection to a PLC backbone. The entire

village is connected via the power distribution system to this backbone. The system has been tested in some public buildings like schools, post office, etc.

The use of an installed infrastructure of a PLC backbone giving direct Internet access to 50 points, many of them directly in common low-income households will permit the development of a iDTV terminal (set-top-box) that is also connected to the PLC backbone and, via a proxy system, to the Internet backbone.

2) The Natz testbed in Italy, near Bolzano. This case includes a PLC network, deployed and tested. The network will cover 20 houses, one school and one hotel. The backbone to internet comes from a DSL line in Bressanone connected through a radio link with Natz. The STB should use this network as return channel.

3 POWER LINE COMMUNICATION (PLC)

3.1 Introduction

The main objective of this section is to introduce the PLC and all technology and concepts involved.

3.2 PLC Coding

There are many forms of modulation that can be used over the Powerline channel, but OFDM is the most suitable since it was the most immune to interference, providing the highest level of spectral efficiency and performance. Specifically, OFDM is very robust against frequency-selective fading channels and large time spreads. OFDM is a special case of multi-carrier transmission that uses several sub-carriers to communicate. It is both a modulation and a multiplexing technique. Using more than 1000 carriers offers the flexibility that if a carrier is working in a space with a lot of interference on that carrier then it can be disregarded while transmission continues for the remaining carriers, thus avoiding this interference and ensuring reliable communications.

Most PLC implementation is based on OFDM modulation. OFDM is the technology used in many other communication systems such as ADSL, VDSL, DAB, DVB and 802.11, and others.

The typical frequency division data system divides the frequency band into N non-overlapping frequency channels. The disadvantage of this system is inefficient use of the spectrum.

On the other hand, OFDM uses overlapped sub-channels and orthogonally between different modulated carriers. The orthogonality causes the carriers to be linearly independent and carrier spacing to be a multiple of $1/T$. Entire number of cycles of other carriers in the symbol period T implies that there is no contribution from all but one carrier at the integration. FFT can be used to obtain the contribution of a carrier without crosstalk; OFDM is a sum of sub-carriers that are modulated using any linear modulation such as Phase Shift Keying (PSK) or Quadrature Amplitude Modulation (QAM).

The main advantages of OFDM are:

- Efficient in multi-path fading channels with large time spreads, i.e. Powerline.
- The data rate per subcarrier is adaptable (according to the SNR detected at the subcarrier).
- Interferences (and impulsive noise) only affect some carriers while the remaining carriers ensure reliable communications. Each operation mode has a total of 1000 subcarriers (10, 20 and 30 MHz).

Modulation parameters are adapted in real-time depending on channel quality measurements for each user and for each carrier.

3.2.1 Coding and Channel Quality Monitoring

The PLC equipment to be used employs several coding mechanisms:

- Adaptive per-carrier modulation
- Reed-Solomon Forward Error Correction
- Interleaving
- 4D Trellis Coded Modulation

Optimum values for the coding mechanisms are computed by the PLC modems automatically, depending on channel quality measurements (Signal-to-Noise Ratio, error packets, etc.), although they can be manually configured, enabled or disabled by the network operator using SNMP or by the auto-configuration process.

3.2.2 Bit Error Rate

The bit error rate (BER) is the percentage of bits that have errors relative to the total number of bits received in a transmission, usually expressed as ten to a negative power. For example, a transmission might have a BER of 10 to the minus 6, meaning that, out of 1,000,000 bits transmitted, one bit was in error. The BER is an indication of how often a packet or other data unit has to be retransmitted because of an error. Too high a BER may indicate that a slower data rate would actually improve overall transmission time for a given amount of transmitted data since the BER might be reduced, lowering the number of packets that had to be resent.

On the PLC Modems used, BER characteristics of the technology are fully programmable in order to meet QoS requirements for any services.

The bit-loading algorithms of each node can be configured manually by the network operator, who can make any trade-off between BER and capacity. Default values for BER are 10⁻⁹ for 1500-byte packets, although the configuration can be changed for increasing or decreasing the BER as needed (typical values are 10⁻³, 10⁻⁶ and 10⁻⁹).

3.2.3 Performance

Performance is not only dependent on channel attenuation or noise, but also on the number of taps, so it is difficult to provide a formula that is useful for all environments.

Experiments conducted at laboratory with flatchannel attenuators, a default conservative BER configuration, and an output PSD of -50 dBm/Hz results in a performance of about 30% of specifications.

3.3 Channel Adaptation

The PLC system continuously monitors the channel attenuation and the noise level with a very high spectral resolution. Information from these measurements is used for adapting the modulation parameters per carrier in order to optimize data capacity while keeping a bounded BER.

The network operator can customize several parameters of the adaptation algorithm:

- Algorithm agility
- Modulation thresholds
- Desired BER
- Disabled carriers

On the other hand, the parameters of the Reed-Solomon Forward Error Correction can be configured dynamically to achieve the desired trade-off between capacity and performance.

3.4 Spectral Efficiency

Spectral efficiency or spectrum efficiency refers to the amount of information that can be transmitted over a given bandwidth in a specific digital communication system. It is a measure of how efficiently a limited frequency spectrum is utilized by the physical layer protocol.

For the PLC equipment used, the spectral efficiency is up to 9 bits/sec/Hz, the highest available on the market. The spectral efficiency used depends on the actual channel conditions (SNR). If the SNR of the channel degrades, the system automatically decreases the spectral efficiency in order to guarantee that the BER remains below the specified limit.

3.5 Layer 2 Protocol Description

Most of PLC cards implement layer-1 (PHY) and layer-2 (DLL and MAC) of the OSI reference model. They integrate a Powerline 802.1D-based switch that supports VLAN (802.1Q) and OVLAN (Optimized VLAN), traffic priorities for QoS policies, enhanced Spanning Tree Protocol, Layer-2 MPLS (Multiprotocol Label Switching), and encryption to assure the privacy of all communications.

There are two different MAC modes depending on the actual medium:

- Access: Master/Slave MAC providing guaranteed bandwidth and latency together with traffic priorities and Layer-2 ACKs.

- **Medium Voltage Access:** Mixture of Master/Slave and peer-to-peer, providing guaranteed bandwidth and latency together with traffic priorities and Layer-2 ACKs. It is optimized for the medium voltage power grid topology.

3.6 MAC (Media Access Control)

3.6.1 Access MAC

The ADTDM (Advanced Dynamic Time Division MAC), used at the PLC modem, has been optimized for PLC access scenarios, which includes high-performance, stringent bandwidth reservation, strict traffic prioritization and Class of Service (CoS). It features high efficiency, using frequency and time reuse, and guaranteed bandwidth and latency per node and service. This MAC allows the operator to use a single network to provide differentiated services like broadband Internet access, VoIP and Video on Demand. Traffic priorities can be computed based on IEEE 802.1p, IPv4, IPv6 or TCP fields. Also, patterns found in the data packet can be used to compute the traffic priorities. This efficiency is maintained in the network access mechanism because any node may access the network at any transformer.

3.6.2 Medium Voltage Access MAC

This kind of MAC keeps the Access MAC features but is specially optimized for the specific characteristics (long distance, point-to-point lines, ring-like topologies) and special requirements (very high bandwidth, very low latency, trunk links with high number of data flows) of MV networks.

3.7 Traffic Prioritization

There are eight possible priority levels. Table I shows a list of applications and their priorities.

Priority	Application (Service)
P7	Network Management, Status, Configuration
P6	VoIP
P5	General Application
P4	Multimedia
P3	FTP
P2	Web Browsing
P1, P0	Others

Table I

P7 is the highest priority and should be dedicated to internal signaling. The rest of the priorities are ordered in decreasing latency requirements.

For broadband access service, every priority has an implicit maximum latency and jitter, defined globally in the PLC network. The priority-application pair, as shown in Table XX, is only an example. The user can redefine its priorities. What remains fixed is the maximum latency and jitter associated with each priority, which is defined by the network operator.

Depending on the type of user (premium, best effort, etc.), certain priorities are allowed. For example, a best effort user may only have up to P2 differentiation. For this user, all packets above P2 will be treated as P2. This ensures that even though users can change the priorities associated with each traffic type, the total amount of traffic transmitted/received remains independent.

3.8 Bandwidth Allocation

The QoS mechanism guarantees different bandwidth and latency to different users and different traffic flows. It is possible to reserve bandwidth for each user and application, as long as the addition of the reserved bandwidth of all nodes does not exceed the total capacity of the channel. Bandwidth management is time-based, although efficiency parameters are taken into account. Whenever a node has access to the channel, it transmits with the highest spectral efficiency allowed by its SNR in each carrier (otherwise channel capacity would be wasted). The flexibility is endless with the only limit being Shannon's law: all of the resources of the channel cannot be allocated to a given user all of the time without having other unhappy users.

3.9 QoS Quality of Service

QoS mechanism guarantees on a per user basis that the user will have the following:

- Guaranteed bandwidth for services that need it (file transfer, etc.).
- Bounded latency for services that need it (Return Channel, Web, VoIP, video conference, etc.).
- Low Bit Error Rate (BER) for services that need reliable channels.
- Guaranteed availability for critical services (Return Channel, etc.), even with changing channel conditions.

3.10 Security

The transmission of data over Powerline is safer than most communications methods. It is easier to intrude on information being sent through commonly wired communication media.

The security model combines up to five of the following protection methods:

- User Authentication and Authorization: Since the access system is Master-Slave based, any Slave node that wishes to connect to the network, and thus have access, must be recognized and authorized by the network Master. This authorization process is done with encrypted communication and is therefore considered secure. Any Slave node that has not been explicitly authorized to connect to a network will not be assigned any resources on the network, and all transmissions it may attempt will be disregarded.
- Encryption Method: PLC modem offers a combination of 3DES and DES encryption. The procedure ensures very strong security by using 3DES encryption for long-term information (encryption key) and a short key life (one single data burst) for DES encryption, thus keeping hardware costs low.
- Real-time Variable User-specific Modulation: Any message that is transmitted on a Powerline network is modulated according to the SNR measured at each connection, and this is changed in realtime as line characteristics change. In order to demodulate a message addressed from one user to another, the exact modulation used must be known, which means that an eavesdropper would have to intercept both upstream and downstream communications. In order to do this, the eavesdropper would need an SNR in the entire frequency band equal to, or better than, the equipment from which he or she is trying to intercept. In addition, the modulation information is encrypted, thus making eavesdropping a very difficult task.
- PLC modem technology also supports 802.1Q VLAN, which effectively isolates all users from each other and is completely controlled by the gateway, which is owned and controlled by the network operator. Access to management features of PLC devices can only be gained by means of a restricted access VLAN that can only be used by the network operator.
- Encrypted VPN is available for use on PLC networks.

3.10.1 DES / 3DES Encryption

The 3DES encryption/decryption block embedded in PLC equipment provides total isolation between networks and guarantees the privacy of network users.

It consists of mixed DES/3DES encryption, configurable per PLC port and PLC node. Each connection on the network has a different 56-bit or 168-bit key and encryption can be independently enabled/disabled. The key length is defined at the time of firmware compilation. A key length of 168 bits is only available with firmware that is compiled to support it.

3DES encryption is obtained by passing the data block through the DES cipher block three times, using three different 56-bit keys. International cryptanalysts consider DES and its variant 3DES high security algorithms that can be only broken using exhaustive search methods, also known as brute-force attacks.

3.11 Supported Services

The PLC technology architecture is packet-oriented, so it is well suited for all packet-oriented services. It can manage real-time traffic, including (but not limited to) Interactivity, system controlling, Voice over IP (VoIP) and Video over IP with Quality of Service management. This management can be done using a DHCP client to download configuration files or via SNMP.

There are no limitations to the services that can be provided over Powerline technology, as long as the throughput and latency needed for these services are feasible according to the characteristics of the technology.

Services that can be provided include the following:

- High-speed Internet access
- VoIP
- Video on Demand
- Audio on Demand
- Real-time TV streaming
- Interaction Return Channel
- Video conferencing
- Video surveillance systems
- Online gaming

3.12 PLC Configuration and Network Management Mechanisms

The configuration and management of PLC network are addressed from two different points of view. The first one is related to facilitating the deployment of large PLC networks. Therefore, all nodes can have their networking parameters, like IP address, default gateway or subnet mask, automatically configured from a central management system using DHCP. The embedded DHCP client also supports configuration file downloading, reducing even further the effort needed to manage the network. The VLAN, OVLAN and QoS configuration of each node is stored in a central database, and the modem downloads the updated configuration every time it boots.

The second concern is the ability to allow OEMs, System Integrators, Utilities, and Service Providers to leverage existing management tools. Therefore, all PLC equipment can be remotely managed using SNMP.

3.13 Radiation and EMC

The strength of radiated electric fields is very dependent on the injection mode and electrical cabling type and topology. Large variations can be expected. Nevertheless, for all PLC equipment used, the FCC Part 15 limits are always met, even in the very worst cases (e.g. higher frequencies and close proximity to the transformer injection point with overhead cabling).

The spectral distribution of the transmission output voltage is a flat level up to 30 MHz bandwidth that can be placed anywhere from 1 to 34 MHz. The voltage level is flexible.

The system has the ability to configure the output power on a carrier-by-carrier basis. That is to say, the output power mask can be programmed as required. This feature allows the system to achieve spectral notches with the bandwidth and depth required.

3.14 PLC Architecture Overview

This section presents the PLC network architecture overview considering basic and most common implementations and some parameter issues that must be considered for adequate configuration.

3.14.1 Network Topology

A PLC network topology is configured from the application and services required. Most of PLC network implementation cases make use of a basic set of equipments and topology to provide the common service required. The figure 3 shows sample architecture used.

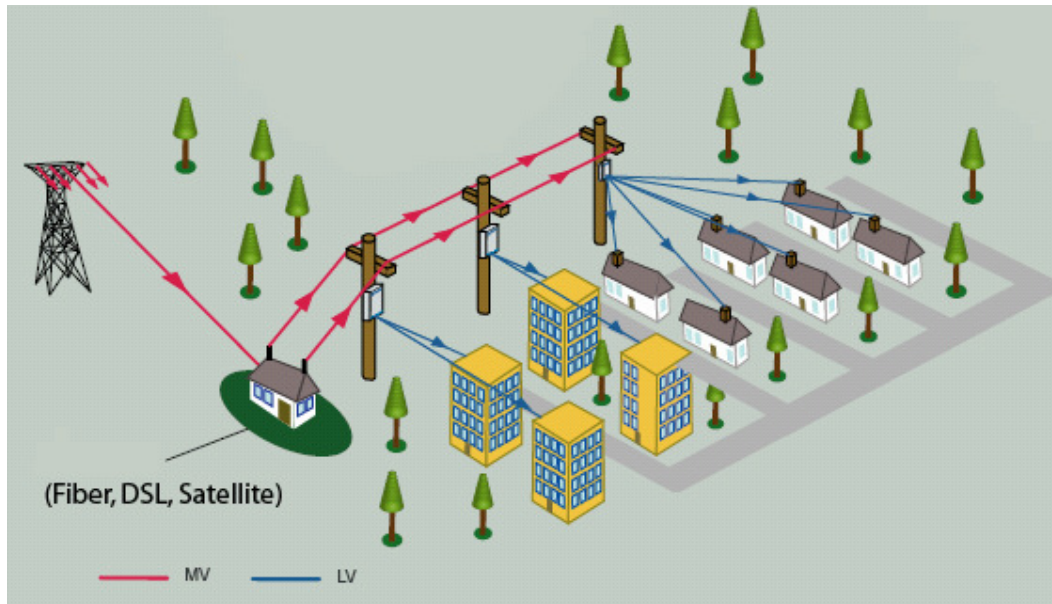

Figure 3 – PLC network sample

At the left side of the diagram, a Gateway connects the Broadband channel and the PLC network. An embedded high-performance Switch eliminates the need for an expensive router, greatly reducing the cost of the backbone network. In addition to its PLC core, the forwarding engine features all the networking capabilities needed for a backbone node: large MAC look-up table (262144 entries), Layer-2 MPLS, 802.1Q VLANs and OVLANS.

In the second level of the diagram, a Gateway connects the MV network and the LV network, bypassing the transformer. An optimized Spanning Tree Protocol provides fast reconfiguration of network changes even in complex ring or mesh topologies typically found in hybrid MV/optical networks. The number of entries in the MAC table (1024) and the 802.1Q VLAN and OVLAN capabilities make this an ideal high-performance MV/LW gateway.

In the third level of the diagram, several devices are connected to the LV network:

- CPE (Customer Premises Equipment) devices that connect end users to a PLC access network, and MDU Gateways that connect a PLC in-home network to a PLC access network.
- Home networking devices, like Ethernet-to-PLC or USB-to-PLC bridges, that the user can use to connect several computers, share printers, ADSL or cable modem connections. Targeted products also include High-Definition TV distribution systems, video surveillance systems and Hi-Fi equipment.

In an access network, the PLC adapters typically work in a master-slave configuration. The network presents a tree-like topology, where nodes placed closer to the tree root will behave as masters of those below them in the hierarchy. Thanks to the collision-free, master-slave MAC (Medium Access Control), a high system capacity is achieved, allowing network operators to provide high bandwidth services, like broadband Internet access or Video on Demand. In addition to this, its QoS features satisfy the stringent quality demands of VoIP applications.

3.14.2 Class of Service Configuration

The Class of Service (CoS) is computed for all packets from input interfaces to Powerline output interfaces. The computation of the priority is done by means of a set of rules programmed by the firmware and stored in the configuration block.

If the packet comes from external interfaces, the packet might be pre-classified. This means that priority computation is unnecessary. The frame is supposed to be correctly prioritized. The proposed system for computing the priority of each Ethernet frame is as flexible as is possible without adding increased complexity. This system is based on a structure of criteria. There are two different criteria for computing the priority. The selection of one criterion depends on the match of a determined field of the Ethernet frame with a pattern. Once the criterion is chosen, the priority is computed following the parameters of that criterion.

This method of prioritization allows for the priority-computing of different packets using different fields and bit patterns. For example, whether a packet is an IP packet or not can make a difference in the computation of the priority. So, if the Ethernet frame contains an IP packet, it can be prioritized by reading, for example, the Type of Service field, but any other field can be read to determine the priority if the packet is not an IP packet (which would mean that it does not have a TOS field).

Each criterion has the following parameters:

- Parameters to see if the frame is the type of packet to apply one of the criteria are:
 - Offset from the beginning of the frame (type of packet offset)
 - Bit pattern for comparing with the frame field (type of packet pattern)
 - Bitmask of bits that must be equal in the bit pattern and in the frame (type of packet bitmask)
- Parameters to compute priority (the CoS) once the frame matches a criterion:
 - Offset from the beginning of the frame (class of service offset)
 - Set of patterns to compare with the frame field chosen with the offset (class of service patterns)
 - Bitmask of bits that must be used for computing the priority (class of service bitmask)
 - Relationship of each pattern with a priority (class of service assignation)

With this architecture, different parts of the frame can be used to detect whether a criterion can be used and for computing CoS.

The firmware can program more than one criterion. The order in which the criteria are evaluated is important, because a frame can be classified using more than one criterion. If no criterion matches, a default priority is assigned to the frame. If one criterion can be applied, no more criteria are evaluated, and the priority assigned is the priority computed with this criterion.

3.14.3 Limiting MAC Addresses

The objective of limiting MAC addresses is to limit the maximum number of End User devices that can connect to a PLC node. The Limit MAC functionality allows three different MAC addresses to connect to one PLC node. Because the Limit MAC limits the number of End User devices that can connect to a PLC node, a packet going from Powerline interface to another Powerline interface does not have a filter.

Bridge learning is used to learn allowed MAC addresses. The traffic to and from the firmware (using a firmware MAC address as the source or destination MAC address) is always allowed.

The Limit MAC function contains the following parameters:

- List of MAC Addresses: This list has three MAC addresses. Used when ingress or egress MAC filtering is active.
- Ingress MAC Filtering Active: If active, and if the packet is from interface, and the source MAC address is not in the list of MAC addresses, the packet is dropped.
- Egress MAC Filtering Active: If active, and if the packet is to interface, the packet is dropped if the destination MAC address is not in the list of MAC Addresses.

3.14.4 Quality of Service

The main objective of Quality of Service (QoS) is to guarantee bandwidth and latency of different users and traffic flows. The incoming flows are stored using the Class of Service (CoS).

User QoS profiles specify a maximum throughput and the maximum latencies granted to each priority (a priority can be assigned to a type of traffic application). The master node knows the QoS parameters of its slaves so that it can ensure the SLA (Service Level Agreement) of every end user is met through the transmission of the token.

Master nodes perform jitter control, priority sniffing, idle user detection, buffer space allocation, bandwidth management, bandwidth limitation, call access control and QoS parameter management to ensure the QoS of every accepted Slave. On the other hand, Slaves perform priority management, buffer space allocation, bandwidth limitation and some QoS parameter management.

Every priority has an implicit maximum latency and jitter, defined globally in the PLC network. What remains fixed is the maximum latency and jitter associated with each priority, which is defined by the network operator. Depending on the type of user (premium, best effort, etc.), a maximum priority will be allowed.

The upstream and downstream transmissions are multiplexed in time. For this reason, the minimum guaranteed latency of a single port in the upstream will be the downstream transmission length, and vice versa, regardless of the number of priority levels used.

On the Master node, the Downstream Bandwidth is limited the buffering of each remote user. The Master node can also limit the downstream bandwidth by limiting the number of bytes that can be transmitted to each Slave.

The Upstream Bandwidth can be limited either on the Slave node or on the Master node:

- The Master node can limit the upstream bandwidth by controlling the percentage of upstream bandwidth used by this Slave. This can be done because the Master sets the new upstream transmission percentage at the end of each upstream time.
- Slaves can also limit their upstream bandwidth by limiting the number of bytes that can be transmitted upon reception of a token, or by limiting the transmission buffer.

The Downstream Latency management deals with the selection of the ports that are going to transmit during the current transmission period. Downstream transmission can be divided depending on the priority.

The Upstream Latency management deals with the distribution of tokens. Depending on the frequency and arrival time between two tokens, upstream latencies can be guaranteed.

4 PLC Return Channel Requirements - Barreirinhas and Natz

This section shows the requirement issues for PLC-RC to be used at Barreirinhas e Natz Test Bed sites. The requirements were obtained from the use of well-known method to dimensioning network throughput considering services, media and network management packages, which were conducted at WP3.

Other information was obtained from the Electric Power Company and from the PLC device manufacturer.

4.1 Return Channel

The return channel should support the transmission in both directions of the text files, xml files and photos. The biggest files are the photos, but the end device is the TV. In this sense, the average dimension should be less than 100 KB. Considering this, a return channel that is capable to transmit this type of photos in 2-3 seconds is sufficient. Thus, the minimum transfer rate to reach should be maximum 500 kbps.

4.2 PLC and QoS Specifications

Regarding the PLC return channel, some performance and QoS characteristics will be presented, taking as reference the standards and some technical measurements carried out during several previous technical works.

4.2.1 Bit Error Rate

The Bit Error Rate (BER) characteristics of the technology are fully programmable in order to meet the QoS requirements for any services. The bit-loading algorithms of each node can be configured manually by the network operator, who can make any trade-off between BER and capacity. Default values for BER are 10⁻⁹ for 1500-byte packets; although the configuration can be changed for increasing or decreasing the BER as needed, (typical values are 10⁻³, 10⁻⁶ and 10⁻⁹).

4.2.2 Performance

Performance is not only dependent on channel attenuation or noise, but also on the number of taps. Thus, it is difficult to provide a formula that is useful for all environments.

The following table (Table II) shows laboratory measurements performed with flat channel attenuators using one Ethernet 100 port as the output interface, a default conservative BER configuration, and an output PSD of -50 dBm/Hz for the 10 MHz mode and -56 dBm/Hz for the 20 and 30 MHz modes:

Attenuation	Throughput (Mbps)	Bandwidth (MHz)
40	44	10
	62	20
60	30	10
	35	20
	48	30
70	13	10
	9	20
	11	30

Table II – PLC Performance vs Attenuation

4.2.3 Spectral Efficiency

One of the maximum spectral efficiency is up to 9 bits/sec/Hz. The spectral efficiency used depends on the actual channel conditions (SNR). If the SNR of the channel degrades, the system automatically decreases the spectral efficiency in order to guarantee that the BER remains below the specified limit.

4.2.4 Maximum Throughput

The spectral efficiency mentioned above is measured at the physical layer and with optimum channel conditions. The throughput at the application layer is lower due to protocol header overheads and error correction overheads.

Therefore, the application layer numbers, measured with FTP and optimum channel quality conditions, are as shown in Table III.

Mode Bandwidth	FTP Throughput
10 MHz	48 Mbps
20 MHz	90 Mbps
30 MHz	130 Mbps

Table III – Max Throughput at the Application Layer

4.2.5 Field Measurements

Below is presented some information about the performance gathered from a number of tests carried out by Homeplug Powerline Alliance [HOMEPLUG].

The tests were carried out in 472 homes in USA, using a total of 6,690 wire paths. Fifteen companies participated in the testing, with the tests being gathered in a variety of geographical areas in the lower 48 states of the US and Canada.

Several kind of tests were implemented, with two nodes and several nodes. The following results were obtained (Table IV):

	% of Connections exceeding 5 Mbps	% of Connections exceeding 1.5 Mbps
IPT 32 (UDP-like) Throughput	77%	98%
TCP IP extrapolated Throughput	73%	97%

Table IV – Two-node field tests

Also, other information has been obtained from the tests:

- The tests showed also that houses with a surface of more than 2,000 of square feet suffer from a loss of an average of 10% in bandwidth;
- Considering the age of the house, the loss of bandwidth was less than 10%;
- The packet loss was registered to keep less than 1% for 99% of the tests;

In the case of five-node field test figures are as shown in Table V:

	% of Connections exceeding 3 Mbps
Aggregate IPT 32 (UDP-like) Throughput	93%
Aggregate TCP IP extrapolated Throughput	90%

Table V – Five node field tests

5 PLC Return Channel Architecture

5.1 Introduction

This section intends to present the network architecture for the Return Channel based on Power Line Communication proposal, which was developed taking in account all functional and technical requirements of the two test bed sites, Barreirinhas and Natz.

The activities necessary for achieving this goal are:

- Analysis and characterization of the PLC network infrastructure to be able to integrate the various backbones involved (IP Public Backbone, Village Metro PLC Backbone, etc.) and to allow the implementation of PLC based iDTV interaction channel.
- Identification of the necessary mechanisms for user interactivity using PLC network as iDTV return channel, and maintain the synchronism between the source of the content or application and the end user.
- Return Channel throughput for achieve all interactive services and for transmitting additional data such as network management information from the terminals; data related to the interaction between service and consumer; and feedback information about services.

5.2 Design considerations

For the IDTV and PLC-RC, the SAMBA project considers two test bed sites. One of them is the Barreirinhas City located at Maranhão State – Brazil. The second one is the Natz city at Bolzano County – Italy.

After the results obtained from WP2 works [SAMBA D.2.1.1], there were verified that the two sites service requirements are quite different. Based on that and on actual electric power lines at each site, the design of the PLC-RC architecture was implemented in separate way.

The following sections present the design of Barreirinhas PLC-RC architecture and Natz PLC-RC architecture respectively.

5.2.1 Barreirinhas Site

Barreirinhas is a fisherman low income small town with economy based on the fisherman activities (at the sea) and some tourism, the people that live in Barreirinhas has the TV watching habit, and some difficulty to access the Internet service. Other characteristics are that every home is connected to the electric power grid, and the local electric power operator and Brazilian Association of Electrical Equipment Industries – APTEL have implemented an experimental PLC network in the Barreirinhas town, that aims to show the applicability of the PLC network for enhance the electrical power services. Figure 4 shows an aerial picture of Barreirinhas.



Figure 4: Barreirinhas aerial picture

The electric power network that covers the main streets of Barreirinhas is shown in the figure 5. In the figure, the PLC-RC network is implemented to reach the users listed in [SAMBA D.2.1.1] and limited to red line circle area.

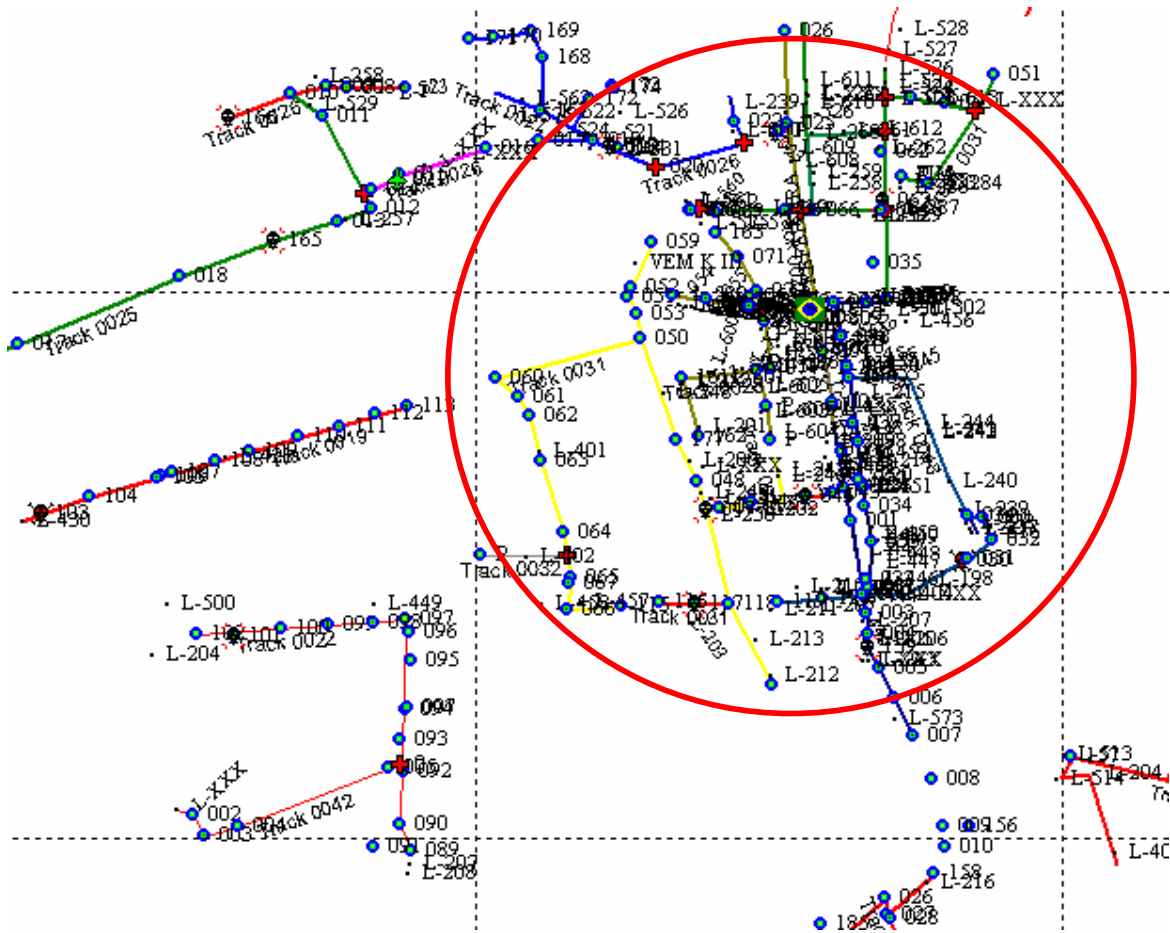

Figure 5: Electric power network and PLC-RC area

5.2.2 Natz Site

Other Test Bed site of SAMBA project is at the South Tyrol region in Italy, where the PLC network was deployed specifically in the Natz city. Figure 6 shows a picture from the region.



Figure 6: South Tyrol region picture

The electric power network of Natz is shown in the figure 7. The AE “Azienda Elettrica” of Bressanone implemented a PLC network, which includes about 20 users in the 500 m of Powerline and a ADSL backbone.

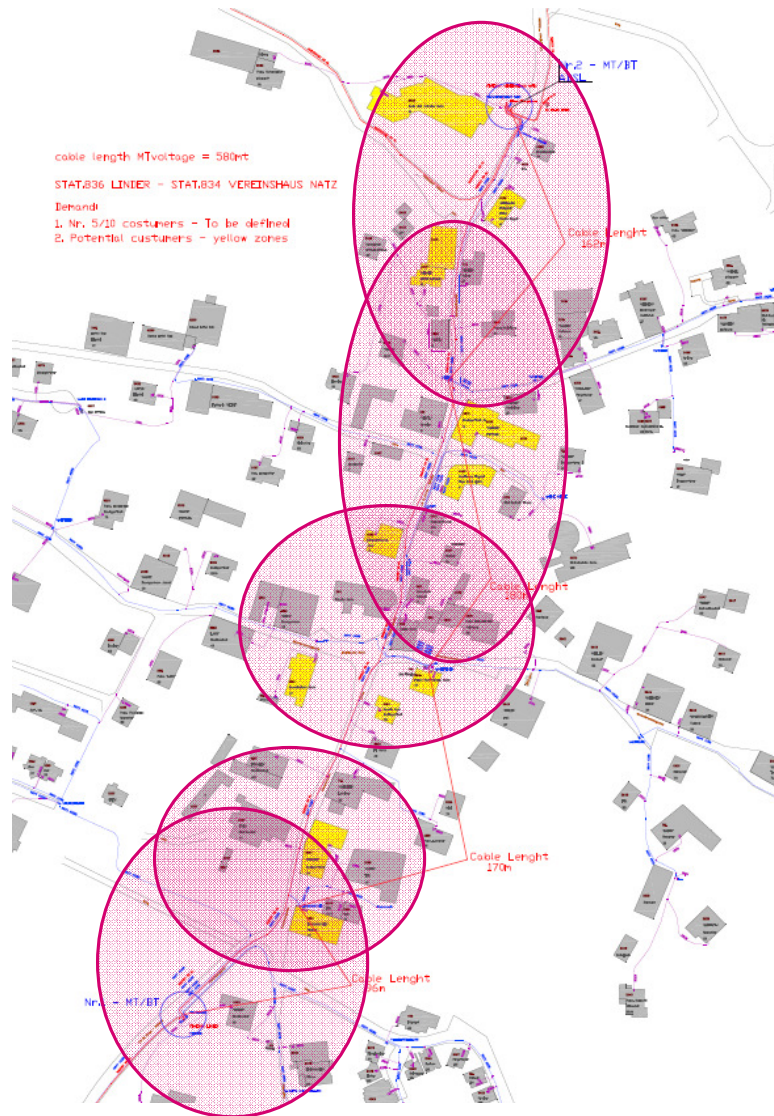

Figure 7: Powerline Infrastructure - Natz

5.3 PLC-RC Architecture Proposals

This section presents the PLC-RC architecture proposals for Barreirinhas test bed site and for Natz test bed site.

5.3.1 PLC-RC architecture proposal for Barreirinhas

Taking in account the overall network architecture shown in the figure 2, the user needs document [SAMBA D.2.1.1] and actual electric power network (figure 5), the following architecture is proposed for the Return Channel for IDTV based on PLC (figure 8).

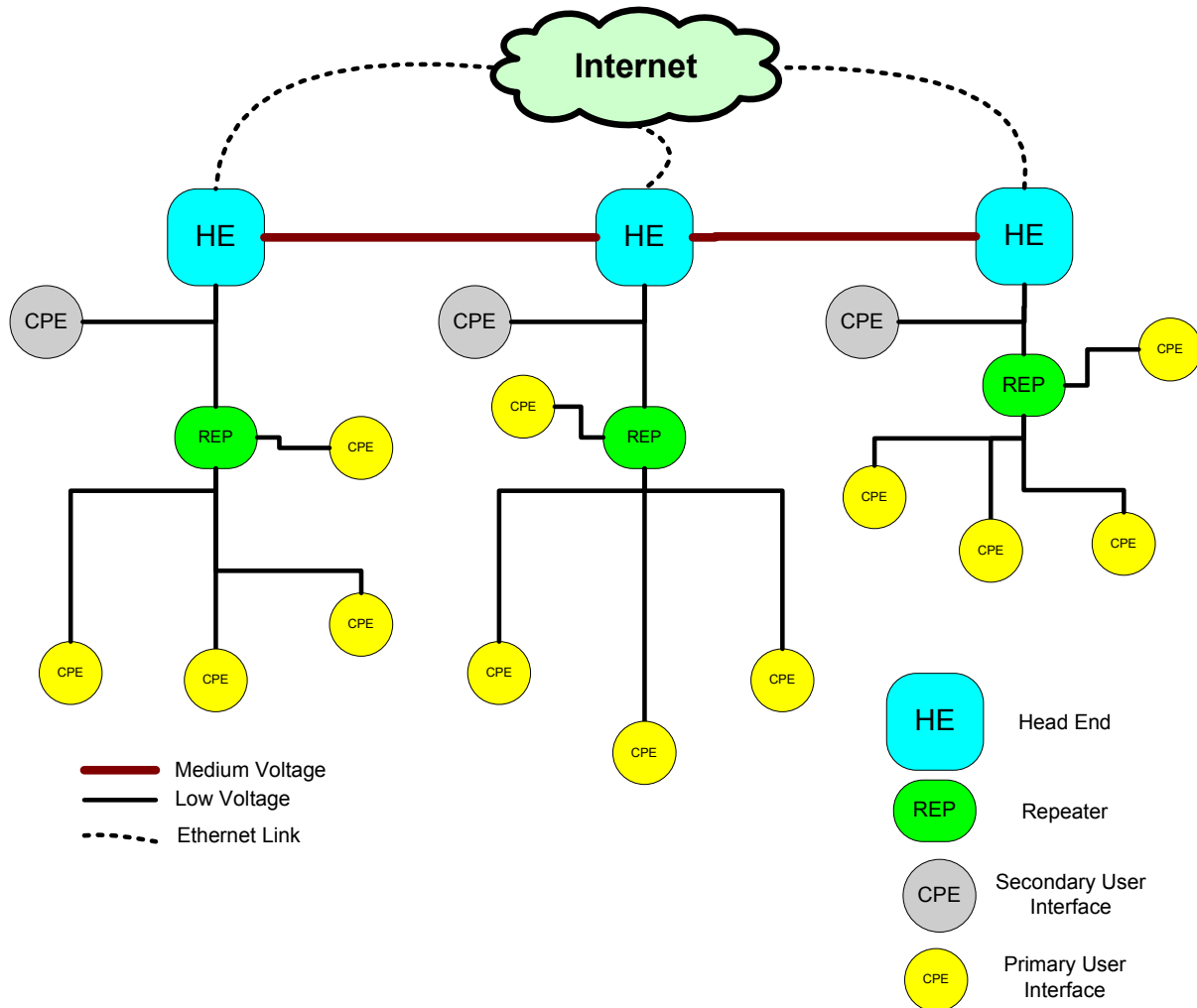

Figure 8: PLC Network Architecture - Barreirinhas

In the Figure 8, the connection between the three HE is mainly over Medium Voltage Power Line. However, in other scenario it is possible to make the connections through Low Voltage Line. The distance between HE is up to 500m., which is the actual distance between users site at the low voltage segments. In the same way, Repeaters (REP) may be used if the distance of CPEs is bigger or if the channel quality must be improved, reducing BER and improving performance. Also in the figure, gray balloon CPEs represents the Secondary User (User that input information, such as content and several Medias, and receives large amount of messages and connections) Interfaces, which requires higher bandwidth and better network service qualities. The yellow balloon CPEs represents the Primary User interface, which comprises all other kind of SAMBA users. Primary Users will use the communication channel mainly for interactive services.

5.3.2 Technical Specification and PLC Infrastructure for Barreirinhas

Considering the architecture proposed in section 5.3.1 and actual market equipments, the following PLC infrastructure will be implemented for Barreirinhas Test Bed site. (figure 9)

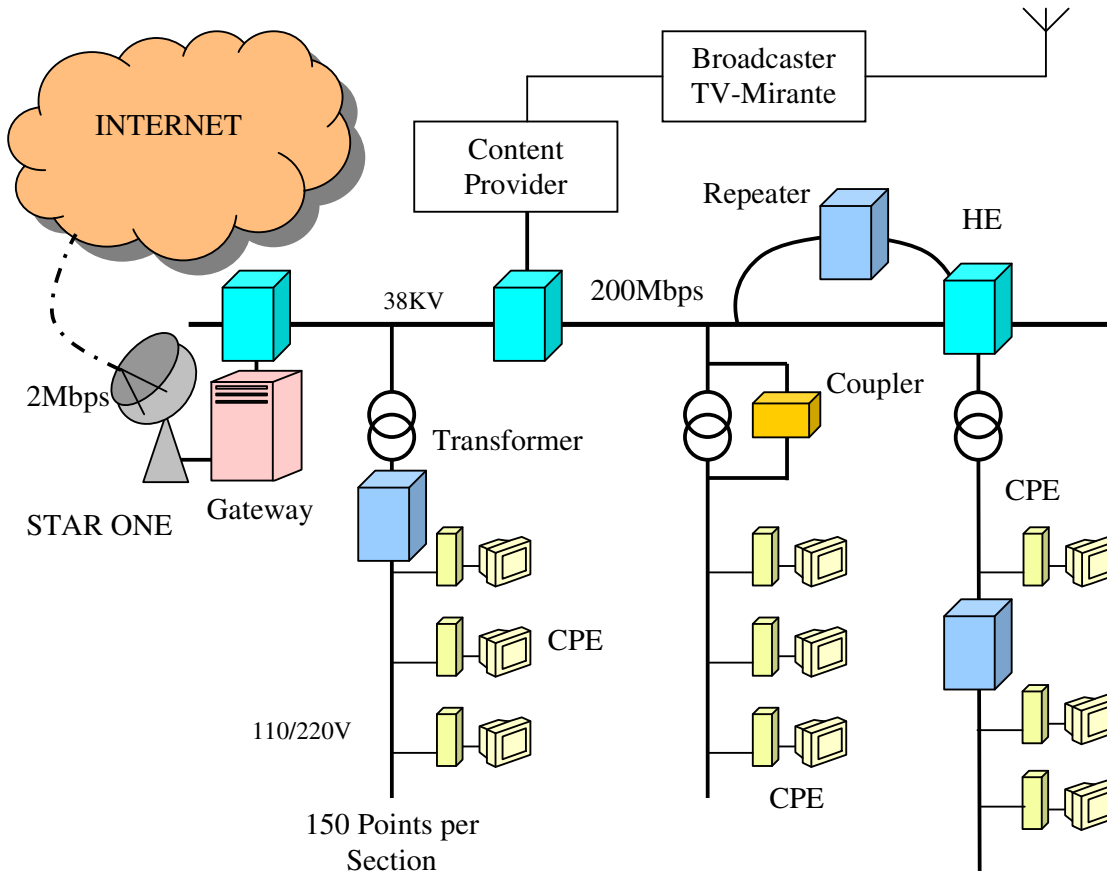

Figure 9 – PLC Infrastructure - Barreirinhas

Technical Specifications

Standards Compliance	IEEE 802.3u, 802.1p, 802.1q, UPA-compliant
Backbone Speed	Up to 200 Mbps
Frequency Range	2 – 34 MHz
Transmitted Power Spectral Density	-50 dBm/Hz

Table VI – Technical Specifications

Features

- 200 Mbps backbone data rate with distances of up to 2 kilometers per regenerator;
- Distance between router and modem up to 300 meters;
- Security with DES / 3DES encryption
- Remote management capabilities with SNMP protocol support
- Bridging support for up to 2048 MAC addresses
- Integrated 802.1D Ethernet Bridge with Optimized Spanning-Tree Protocol
- 8-level priority queues, with programmable priority classification engine

5.3.3 PLC-RC architecture proposal for Natz

Taking in account the overall network architecture shown in the figure 2, the user needs document [SAMBA D.2.1.1] and actual electric power network at Natz (figure 7), the architecture in figure 10 is proposed for the Return Channel for IDTV based on PLC. The technical specifications and features for this testbed are the same as the system deployed in Barreirinhas.

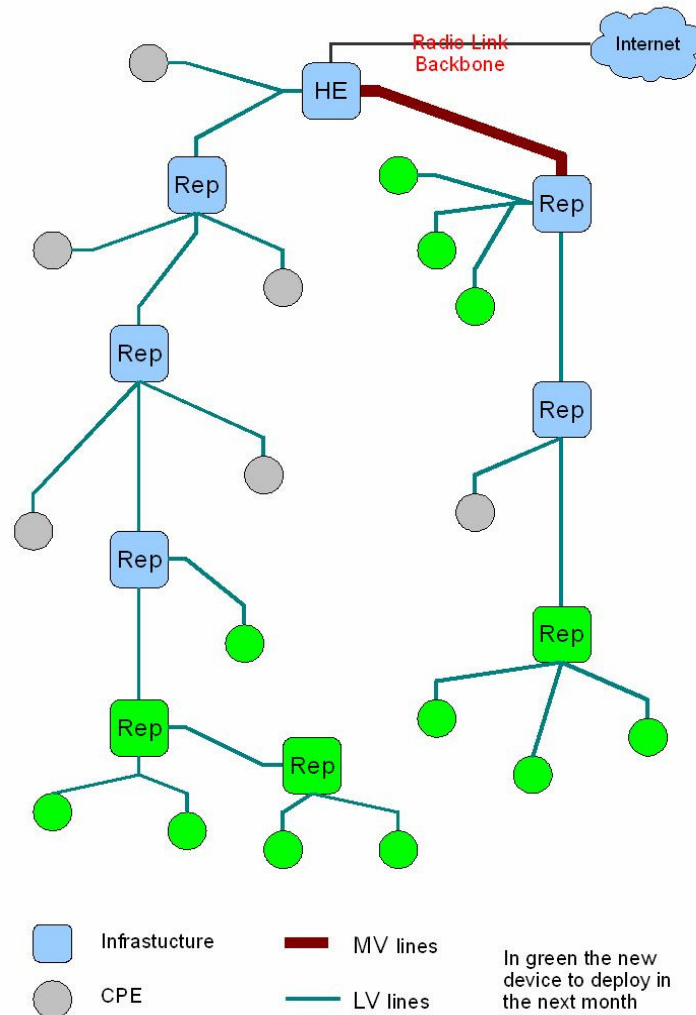

Figure 10: PLC Network Architecture - Natz

6 Conclusion of PLC architecture for SAMBA

This document presented a proposal of architecture for the Return Channel (RC) over Power Line Communication (PLC) to provide an efficient and low cost Interactive channel of Digital TV services at SAMBA project.

The methodology used considered the analysis of requirements, the Powerline infrastructure and PLC equipments and the network project specification, especially one from WP3.

Section 5 presented the PLC-RC architecture for both SAMBA Test Bed sites, Barreirinhas and Natz. Also, a implementation scenario was shown considering the architecture, actual Powerline infrastructure and PLC equipments from market.

7 Summary of the document

SAMBA Architecture

General Architecture: Architecture that includes all equipments and, infrastructure and players

PLC Return Channel: The use of PLC as Return Channel for Interactive Digital TV

Power Line Communication (PLC)

Technology: Shows technology involved in the PLC, such as OFDM, MAC, DES, etc

PLC Architecture: Usual PLC applications and related network topology

PLC Return Channel Requirements

Return Channel: Requirements and constraints for IDTV Return Channel. Support the transmission in both directions, maximum transfer rate 500 kbps.

PLC and QoS: Equipments and services specification. BER characteristics of the technology are fully programmable in order to meet QoS requirements for any services. It is difficult to provide a formula for performance that is useful for all environments.

PLC Return Channel Architecture

PLC-RC: Architecture proposal for Barreirinhas test bed site

PLC-RC: Architecture proposal for Natz test bed site

PLC Infrastructure: PLC implementation overview considering actual Powerline and equipments